

## 2 Tartım 6 İstasyon Karoser Un Paketleme Makinesi

Flour Bagging Machine With Double Weigh Hopper & Six Stations



## 2 Tartım 6 İstasyon Karoser Un Paketleme Makinesi

Flour Bagging Machine With Double Weigh Hopper & Six Stations

10/25/50 kg.



**10 Kg**  
**1000**  
Paket/Saat  
Package/Hour

**25 Kg**  
**900**  
Paket/Saat  
Package/Hour

**50 Kg**  
**850**  
Paket/Saat  
Package/Hour



4 Haneli Tartım Miktarının Gösterimi  
4 Display Indication of the Weighing Quantity



Programlanabilir Tolerans Değerleri  
Programmable Tolerance Values



Paket Yapılan Toplam Ürün Miktarı Gösterimi  
Total Product Quantity Packaged



Dolum Yapılan Toplam Paket Miktarı Gösterimi  
Total Package Quantity in which filling is made



Üst Hazne Seviye Kontrolü  
Upper Hopper-Reservoir Level Control



Kullanıcı Uyarı Bilgilendirmeleri  
User Warning Information



Opsiyonel Paket Ölçüleri  
Optional Package Sizes



Hata Bildirimi ve Kontrolü  
Error Notification and Control



Hızlı – Yavaş Devir  
Fast – Slow Cycle

## GENEL ÖZELLİKLER / GENERAL FEATURES

**Kapasite Bilgileri:** Torbalanacak ürüne ve istenen toleransa göre değişmekle birlikte aşağıdaki paketleme hızı ile ilgili değerler sistemin kapasitesi hakkında bir bilgi verecektir.

- 10 kg'lık Paketlemelerde 10 ton/saat
- 25 kg'lık Paketlemelerde 22,5 ton/saat
- 50 kg'lık Paketlemelerde 42,5 ton/saat

50 kg'lık paketlemelerde paket başına tolerans  $\pm 0,15$  kg arasında değişir. Ayrıca, paket başına düşen ortalama hata payı ile un veya benzer karakterdeki ürünlerde 42,5 ton/saat kapasite ile çalışması taahhüt edilir.

**Paketleme Set Değerleri:** Paket dolum ağırlıkları operatör tarafından 10 - 25 - 50 kg arasında tercih edilebilmektedir.

**Capacity Information:** While it varies according to the product to be bagged and the tolerance required, the values relating to the packaging speed below shall provide some information about the capacity of the system.

- 10 ton/hour in 10 kg bagging
- 22,5 ton/hour in 25 kg bagging
- 42,5 ton/hour in 50 kg bagging

The tolerance per package varies between  $\pm 0.15$  kg in the 50-kg packaging. In addition to this, it is undertaken to be operated with 32.5 ton/hour capacity in the products such as flour or in similar characteristics with the average error share per package.

**Packaging Set Values:** The package filling weights could be preferred between 10 – 25 - 50 kg by the operator.

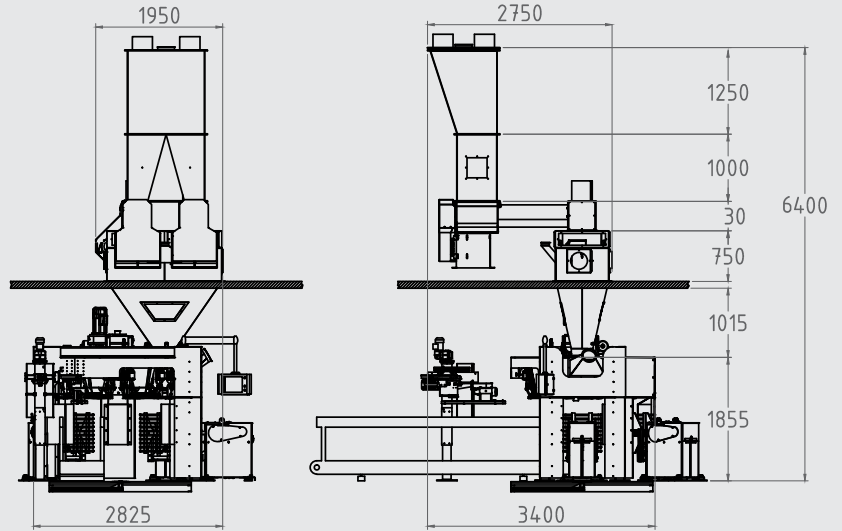

## TEKNİK ÖZELLİKLER / TECHNICAL FEATURES

Ürün Kodu/Product Code: **EE-26UT-102550**

Paketlenecek Ürün Cinsi / Type of Product to Be Packed	Un/Flour	Çıkış Kapasitesi 50 Kg / Output Capacity 50 Kg	42,50 Ton/Saat - Ton/Hour
Yoğunluk (Un) / Density (Flour)	0,55 kg/m <sup>3</sup>	Tartım Adedi 10 Kg / Weighing Units 10 Kg	1000 Paket/Saat - Pack./Hour
Maksimum Tartım Ağırlığı /Maximum Weighing Weight	2 x 55 Kg	Tartım Adedi 25 Kg / Weighing Units 25 Kg	900 Paket/Saat - Pack./Hour
Tartım Aralığı -Seçenekleri / Weighing Range -Options	10 - 25 - 50 Kg	Tartım Adedi 50 Kg / Weighing Units 50 Kg	850 Paket/Saat - Pack./Hour
Tartım Hassasiyeti / Weighing Accuracy	$\pm 0,3$	Hava Basıncı / System Pressure	6 - 8 Bar
Üst Bunker Kapasitesi / Top Bunker Capacity	1.645 Litre/Liter	Hava İhtiyacı / Air Supply (m <sup>3</sup> /Dakika-Min)	40 m <sup>3</sup> /Dakika-Min
Kefe Kapasitesi / Platter Capacity	2 x 110 Litre/Liter	Elektrik Beslemesi / Power Supply (VAC) (+5% - 10%)	400 VAC / 50-60 Hz.
Çıkış Kapasitesi 10 Kg / Output Capacity 10 Kg	10,00 Ton/Saat - Ton/Hour	Elektrik Tüketimi / Electricity consumption	25 kW/Saat-Hour
Çıkış Kapasitesi 25 Kg / Output Capacity 25 Kg	22,50 Ton/Saat - Ton/Hour	Ağırlık / Weight	6350 Kg

# INDUSTRY FOR THE FUTURE

www.medyakim.com



**ENDÜSTRİYEL**

**Endüstriyel Elektrik Elektronik San. ve Tic. A.Ş.**

K.O.S.B. Evrenköy Cd. 3. Sk.  
No:5 Selçuklu/KONYA/TURKEY

T : +90 332 239 09 00  
F : +90 332 239 09 02

endustriyel@endustriyel.com  
www.endustriyel.com

